

	pag
<input type="checkbox"/> Meccanici Mechanical	38, 39.
<input type="checkbox"/> Meccanici da tavolo Table timers	40, 41, 42.
<input type="checkbox"/> Digitali da tavolo Table digital	43, 44.
<input type="checkbox"/> Digitale da incasso Panel digital	45.

CONTAMINUTI

Tipo: **CD360**

SCHEDA TECNICA CONTAMINUTI:

- Tempi di marcia: 15-30-60-120 min.
- Tolleranza su temporizzazione: $\pm 3\%$
- Senso di armamento: orario
- Durata del segnale: 4 sec.
- Temperatura di esercizio: 125°C
- Coppia di manovra a 80°C: carica max 5kg. cm scarica max 4 Kg. mm
- Riserva coppia frizione: 0,3 kg. cm. min.
- Numero manovre: 4.000
- Arco di carica: 360°
- Altri assi su richiesta.

SIGNAL CLOCK

Tipo: **CD360**

TECHNICAL CARD OF SIGNAL CLOCK CD:

- Running time: 15-30-60-120 min.
- Time tolerance: $\pm 3\%$
- Charge direction: hourly
- Signal duration: 4 seconds
- Ambient temperature: 125°C
- Couple at 80°C: charge max 5 kg. cm discharge max 4 Kg. mm
- Friction couple reserve: 0,3 kg. cm. min.
- Charges number: 4,000
- Rotation angle: 360°
- Other shaft on request.

Arco di carica (Angle)

Tipo **CD 360**
Type



ASSE (SHAFT)

Tipo **0033**
Type

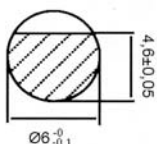

Arco di carica (Angle)

Tipo **CD 360**
Type

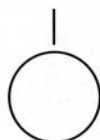

ASSE (SHAFT)

Tipo **0032**
Type

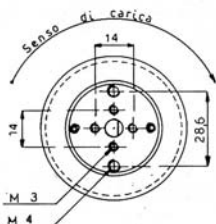
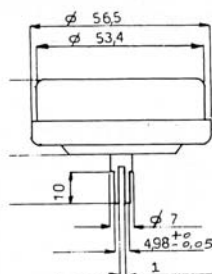
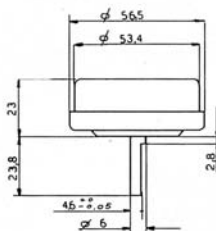
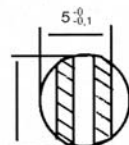

• Rotazione

Arco di carica: 360°
Rotation angle: 360°

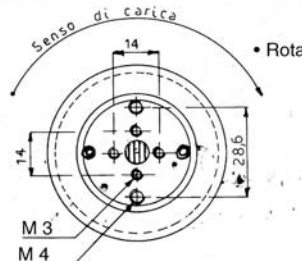

• Rota

MINI CONTAMINUTI

Tipo: 4023

SCHEDA TECNICA CONTAMINUTI:

- Tempi di marcia: 15-30-60-120 min.
- Tolleranza su temporizzazione: $\pm 3\%$
- Senso di armamento: orario
- Durata del segnale: 6 sec.
- Temperatura di esercizio: 125°C
- Riserva coppia frizione: 0,3 kg. cm min.
- Numero manovre: 4.000
- Arco di carica: 360°

MINI SIGNAL CLOCK

Type: 4023

TECHNICAL CARD OF SIGNAL CLOCK CD:

- Running time: 15-30-60-120 min.
- Time tolerance: $\pm 3\%$
- Charge direction: hourly
- Signal duration: 6 seconds
- Ambient temperature: 125°C
- Friction torque reserve: 0,3 kg. cm min.
- Charges number: 4.000
- Rotation angle: 360°

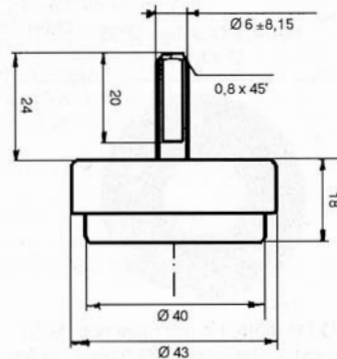
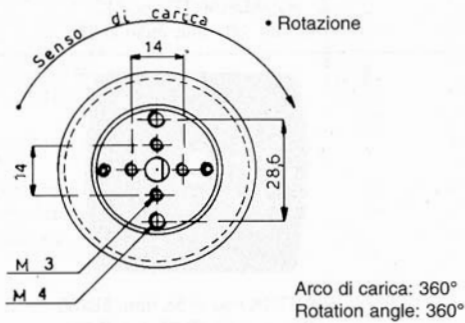
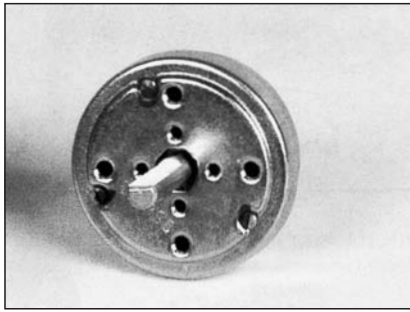

TEMPOMATIC

CONTAMINUTI MECCANICI - 60 MIN.

(altre figure su richiesta)

MECHANICAL SIGNAL CLOCK - 60 MIN.

(other figures on request)



T53



T54



T52



T43



T44



T42



T47



T56



T55

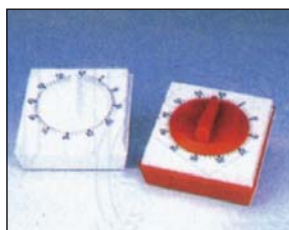

HD20



T21



T85



T97



HD84



HD88

TEMPOMATIC



HD83



HD75



T77



T78



T79



HD46



T82



HD102



HD63



HD73



T41

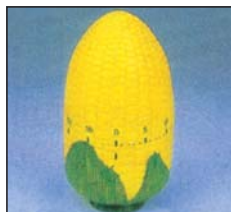

HD36



HD61



HD39



HD68



HD30

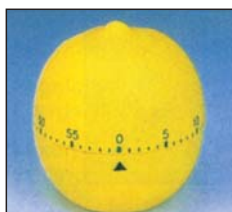

HD33



HD34



HD67



HD38

TEMPOMATIC

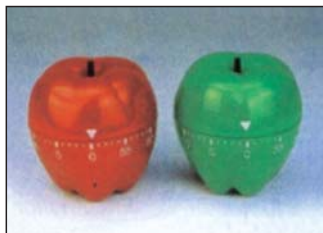

HD32B

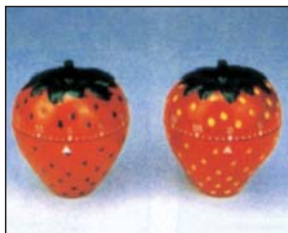

HD35



H31

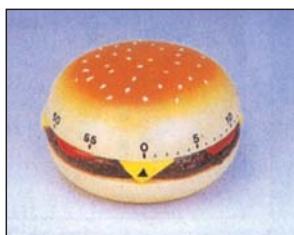

T50



H25



HD66

**CONTAMINUTI MECCANICI
CON CARILLON - 60 MIN.**

(altre figure su richiesta)

**MECHANICAL SIGNAL CLOCK
WITH CARILLON - 60 MIN.**

(other figures on request)



HD101



HD204

CONTAMINUTI ELETTRONICI

Tipo: 870

FUNZIONI:

- Orologio
- Sveglia
- Contaminuti

Grande e chiaro display digitale e cristalli liquidi di semplicissimo utilizzo.

- Contaminuti indietro
- Contaminuti avanti
- Capacità di temporizzazione: 23H - 59 min. - 59 sec.
- Possibilità di bloccare il tempo con il tasto "stop" e farlo ripartire con tasto "start"

ELECTRONIC CLOCK-TIMER

Type: 870

FUNCTIONS:

- Clock
- Alarm clock
- Clock time

A big and clear liquid crystal digital display easy to use.

- Clock time back
- Clock time forward
- Timing capacity: 23H - 59 min. - 59 sec.
- Opportunity to stop the time with "stop" switch to start it again with "start" switch.



Tipo: BIG DIGIT

Conto alla rovescia e cronometro con memoria minuti/secondi. Grande display, munito di sostegno da tavolo e di pratico magnete per appenderlo.

CARATTERISTICHE:

- Altezza cifre: 19 mm
- Dimensioni display: 47 x 21 mm
- Batteria: 1,5 Volt stilo
- Temporizzazione 99 min. 59 sec.

Type: BIG DIGIT

Min-sec count-down and up memory timer Big Digit.
Magnetic back clip, easy stand.

SPECIFICATIONS:

- Digit Height: 19 mm
- Display size: 47 x 21 mm
- Battery: 1,5 Volt
- Timing 99 min. 59 sec.



TIMER DIGITALE COUNT DOWN

Tipo: T006

CARATTERISTICHE:

- Grande display
- Calamita magnetica posteriore per fissaggio
- Batteria LR44x1 (1,5V) inclusa
- Colore bianco o argento

FUNZIONI:

- Conto alla rovescia
- Memorizzazione del tempo impostato
- Azzeramento con la pressione contemporanea dei tasti "min-sec"

DIMENSIONI:

- Corpo: 47 x 17 x 90
- Display: 35 x 12



DIGITAL COUNT DOWN TIMER

Type: T006

CHARACTERISTICS:

- Big display
- Back side magnet for fixing
- LR44x1 battery (1,5V) included
- White or silver colors

FUNCTIONS:

- Count down
- Time set memorizing
- Resetting with "min-sec" button pression

DIMENSIONS:

- Body: 47 x 17 x 90
- Display: 35 x 12

Tipo: 999

SPECIFICHE

- 999-1 min conto alla rovescia con suoneria
- 59-0 sec saranno mostrati dopo l'ultimo minuto
- Il timer smetterà di suonare dopo 15 sec.
- Rimarrà in memoria l'ultimo tempo impostato
- Magnete posteriore per fissaggio
- Clip e corda

MODO D'USO

Per esempio, per impostare 28 min.:

- 1) digitare prima il tasto 2 e poi il tasto 8
- 2) digitare il tasto "START STOP" per iniziare l'operazione

CAMBIARE IL TEMPO IMPOSTATO MENTRE IL TIMER STA OPERANDO

- 1) premere il tasto "START STOP" per fermarlo, il display mostrerà "0"
- 2) dopodichè reimpostare come sopra in "modo d'uso"

BATTERIA: 1 x LR 44/AG13



Type: 999

SPECIFICATION

- 999-1 min countdown with alarm
- 59-0 sec will be shown at the last min
- The timer function will stop after 15 sec alarm sound
- Can recall the last setting
- Magnet on backside
- Clip or pendant option

USAGE METHOD

For example: To set 28 minutes

- 1) Press button 2 & then button 8
- 2) Press "START STOP" button to begin countdown

CHANGING SET TIME WHEN TIMER IS IN OPERATION

- 1) if you want to change timer setting press "START STOP" button to stop counting, and display will show "0"
- 2) Then, set again according to the above usage method

BATTERY: Use 1 x LR 44/AG13

CONTAMINUTI ELETTRONICO CON AVVISO ACUSTICO

Tipo: DL10

CARATTERISTICHE GENERALI:

- Temporizzazione da 1 a 99 minuti o ore
- Funzionante con batteria 1.5V
- Display LCD a due cifre
- Operazioni con un solo tasto
- Segnale acustico a fine conteggio
- Fissaggio ad incastro
- Durata suoneria: 10 secondi
- Temperatura massima: 75°C
- Dimensione cava: mm. 45x25

FUNZIONAMENTO:

- Appena acceso, sul display compaiono le due cifre "00"
- Premere il tasto una volta per impostare il conteggio (1 minuto alla volta)
- Tenere premuto il tasto per far avanzare il conteggio più velocemente
- Quando il tasto viene rilasciato per più di un secondo, il conteggio inizia
- Durante il conto alla rovescia: se il tempo rimasto è maggiore di un minuto, la cifra dei minuti lampeggia sul display, se il tempo rimasto è minore di un minuto, la cifra dei secondi lampeggia sul display. Tenere premuto il tasto per 2 secondi per fermare il conteggio (viene emesso in un beep)
- Quando il conto alla rovescia è finito: le cifre "00" lampeggiano sul display, il segnale acustico viene attivato (10 beep 14 al secondo). Le cifre "00" lampeggiano ancora per 44 secondi, il display si spegne

LCD SIGNAL CLOCK WITH ACOUSTIC SIGNAL

Type: DL10

GENERAL FEATURES:

- Count-down timer can be programmed up to 99 minute or hour
- 1.5V battery operation
- Two digit LCD display
- Single key operation
- When count-down finishes, beep sounds are given
- Fixing: snap in
- Number of beep after count-down: 10
- Temperature max: 75°C
- Hole dimensions: mm. 45x25

OPERATING SPECIFICATIONS:

- As the unit is powered up, all segments go ON for 1 sec
- "00" goes solid in the LCD
- Press the key once to advance the counter by 1
- Press and hold the key to change the setting in 8 steps per second
- During count-down: if the time left is more than 1 minute, its minute section goes flashing in the LCD, if the time left is shorter than 1 minute, its second section goes flashing in the LCD. Press and hold the key for 2 seconds, a beep is given and the count-down process stops immediately.
- When the count-down finishes: "00" goes flashing, 10 beeps which depends on the option selected, are given at 1 beeps per second, "00" goes solid for 44 seconds, LCD goes Off

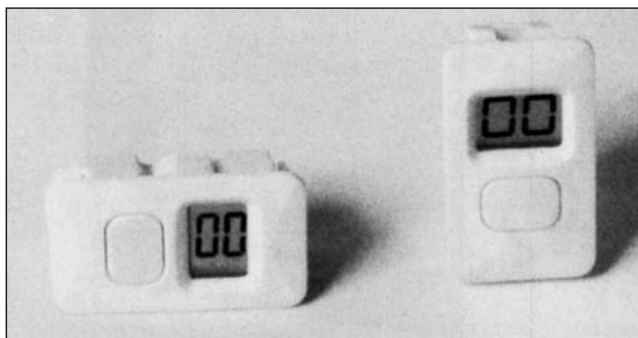

Profondità/Depth: mm. 19

